

Produktinformation

Pressure Converter UNICON-P



- Programming via front side keypad
- For dry and non aggressive gases
- Measuring range programmable
- Output 4..20 mA, 2-wire connection

Characteristics

Pressure converters UNICON-P can be used for measuring low pressure, differential pressure in filter- and clean room technologies. In connection with orifice plates, impact (dynamic) pressure, venturi nozzle it is suitable for measurement of flow rates of dry and non aggressive gases. The model for wet media (condensate-stability device; measuring ranges 30-60) is designed only for relative pressure.

Within the device dependent full scale range, output and display may be adjusted. The device offers additional features like a unidirectional (e.g. 0..1 mbar) or bidirectional (e.g. -1..1 mbar) pressure range. The analog output depends to the programmed analog output.

Technical data

Power supply

Supply voltage : 7.5..30 VDC, 2-wire 4..20 mA,
16..30 VDC, 3-wire 0..10 VDC

Operating temp. : 0..50 °C or
-15..+65 °C condensate-stability device

Storage temperature : -20..+80°C
CE-conformity : EN 61326-1:2013

Input

Process connection
Standard device : 2 pressure tubes for 4 mm
hose (standard)
or 4 and 6 mm Schott glands available

Condensate-stability device : 1 Schott gland, 4 or 6 mm
Process medium : see table Measurement / Process media
Measuring principle : Piezoelectric
Conversion rate : 2 / s
Rise time T_{90} : parameter → input filter

	low	med	high
Standard	: 300 ms	7000 ms	41000 ms
Condensate-stability device	: 2000 ms	7000 ms	41000 ms

The accuracy depends to the selected device measuring range, T_k and zero unbalance

Standard device : ± 0.25 % ± 1 Digit
Condensate-forming : ± 0.5 % ± 1 Digit

Output

Current	: 4..20 mA, ext. burden; $R_A[\Omega] \leq (U_B - 7,5 V) \div 0,02 A$
Voltage	: 0..10 V, load < 3 mA, if supply > 16 V; load < 10 mA, if supply > 20 V
Alarm output	
Transistor	: 7.5..30 VDC, max. 60 mA, short circuit proof
Voltage drop	: < 3 V (at maximum load)
Display	: LCD dot-matrix, 2 lines each 16 characters
Conversion rate	: parameter input filter low = 8 / s; med and high = 2 / s;
Case	: field case
Material	: polyamide with fiber-glass PA6-GF/GK 15/15, front foil polyester
Dimensions	: 100 x 100 x 60 mm (HxWxD)
Weight	: max. 360 g
Connection	: screw terminal with pressure plate, 2,5 mm ² flexible, 4 mm ² wire
Protection class	: IP65, terminals IP20 acc. to BGV A3

Measurement / process media

	Standard device	condensate-stability device
Measurement	Pressure relative, absolute, difference pressure ratio / linear	Pressure relative
Process material	Silicon, Nylon, ceramic, Gold	Silicon, Polythermid, Polypropylene, Polyurethane
Median compatibility	Dry, non aggressive gases	Water, alcohol, alkaline cleaning supplies, low acids, and many similar gases
Non median compatibility	All others	Carbon hydride (oil, petrol...), high concentrated acids, depended cleaning supplies

Dimensions

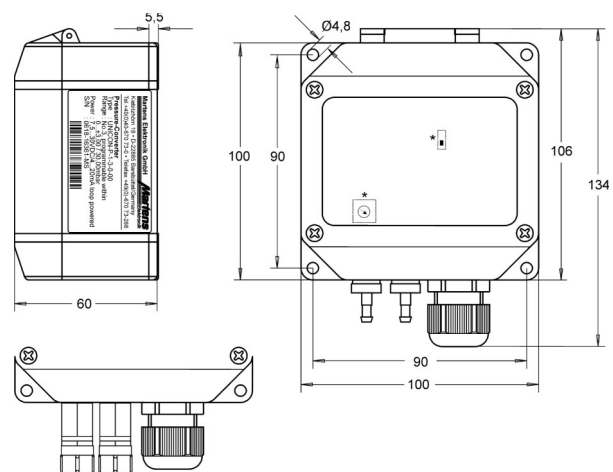

Process port
6mm Schott glands

Process port
4 mm tubes

The condensate-stability device provides only 1 process port with 4 or 6 mm Schott glands.

Produktinformation

Connection diagram

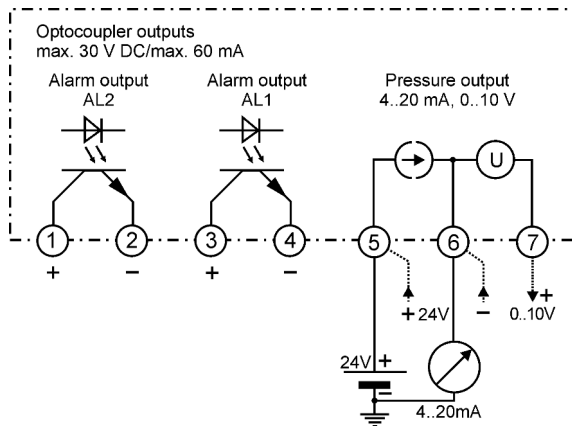

Note:

For supplying the converter use terminals 5 and 6 as shown. If the converter is used for monitoring only, terminals 5 and 6 can be connected directly to supply voltage.

Ordering code

UNICON-P - 1. - 2. - 3. - 4.

1. Model	
1	output 4..20 mA, 2-wire 7.5..30 V DC
2	as 1, but additional output 0..10 V, 3-wire 16..30 V DC
2. Measuring range [mbar] (max. static over pressure)	
Standard	
1	±3 rel. (200)
2	±10 rel. (200)
3	±30 rel. (300)
4	±100 rel. (600)
5	±300 rel. (1000)
6	±1000 rel. (3000)
9	+2000 abs. (4000)
Device for wet media (condensate-stability)	
30	±50 rel. (1400)
40	±100 rel. (1400)
50	±300 rel. (1400)
60	-700..1000 rel. (3000)
3. Process port	
0	4 mm tube (only standard device)
2	4 mm Schott glands
3	6 mm Schott glands
4. Options	
00	without option
06*	display conversion
11*	extended burst pressure (max. 3 bar) only MR 3

* not for wet media